

Infinite is the ultimate in classic modernity, delivering sleek, clean lines, flush fronts and minimalist fittings. This is a contemporary, high quality solution, perfect for the most stylish environments.

infinite

Infinite

Main image

Infinite Veneer cubicles in Fumed Oak Straight Grain, Infinite ColourCoat cubicles in White RAL9003 and Rapiduct WC panelling in Fumed Oak Straight Grain.

See p90-91 for Infinite technical specifications.

Infinite Veneer

Real wood veneers offer a rich, earthy tone to spice up a modern washroom with warmth and texture.



01 Stainless steel indicator bolt faceplate with emergency release mechanism.

02 Sleek stainless steel pedestals.

03 Pedestals are fitted to partitions to give the range its floating appearance.

See p90-91 for Infinite technical specifications.



Main image

Infinite Veneer cubicles in horizontal grain American Black Walnut and bespoke Dupont Zodiaq vanity.

For the full choice of veneers, please visit our website at www.venesta.co.uk, contact our sales team on 01474 353333 or refer to our Colour Selector brochure.



Key features

Flush fronted

Set back pedestals give the cubicles their floating appearance

Minimal look with clean lines

A choice of 11 real wood veneers

Sleek stainless steel and aluminium fittings

Unique emergency release facility indicator bolt

Case Study Sharjah Central Shopping Mall

Infinite Full Height has delivered ultra-modern and sleek washroom facilities to Sharjah Central Shopping Mall in United Arab Emirates.

Sharjah Central is a newly developed two storey retail and leisure destination, offering an enriching shopping experience to the local community in Sharjah, UAE. Boasting a wide selection of shops, restaurants, a 10,000 square metre hypermarket and an extensive entertainment complex, Sharjah Central's mission is to be the ultimate leisure destination for families and entertainment seekers.

Being in close proximity to Sharjah International Airport and Sharjah University City, footfall was expected to be high and steady. With this in mind, Abu Dhabi based management company Lulu Group International required a premium cubicle system which would offer visitors privacy and could stand the test of time too.

Infinite Full Height toilet cubicles were specified in heat, scratch and impact resistant High Pressure Laminate (HPL), an ideal material for heavily used areas. The ultimate in classic modernity, Infinite Full Height delivers sleek, clean lines, flush-fronts and minimalist fittings. 'Cloud' and 'Gunmetal' were the colours of choice for the cubicles, complementing the décor of the modern washrooms.

The cubicle partitions and pilasters are fixed to the floor and ceiling with fixing blocks for style and rigidity in equal measure. Meanwhile, the ceiling to floor cubicles and 20mm door clearances guarantee total user privacy.

The Infinite range boasts sleek stainless steel lever operated indicator bolts that offer quick emergency release from outside of locked cubicles. This means no damage is done to the cubicles or locks in the event of an emergency, which is a key consideration when specifying commercial washrooms in busy settings.

Read the full case study at www.venesta.co.uk



Technical Specifying Infinite

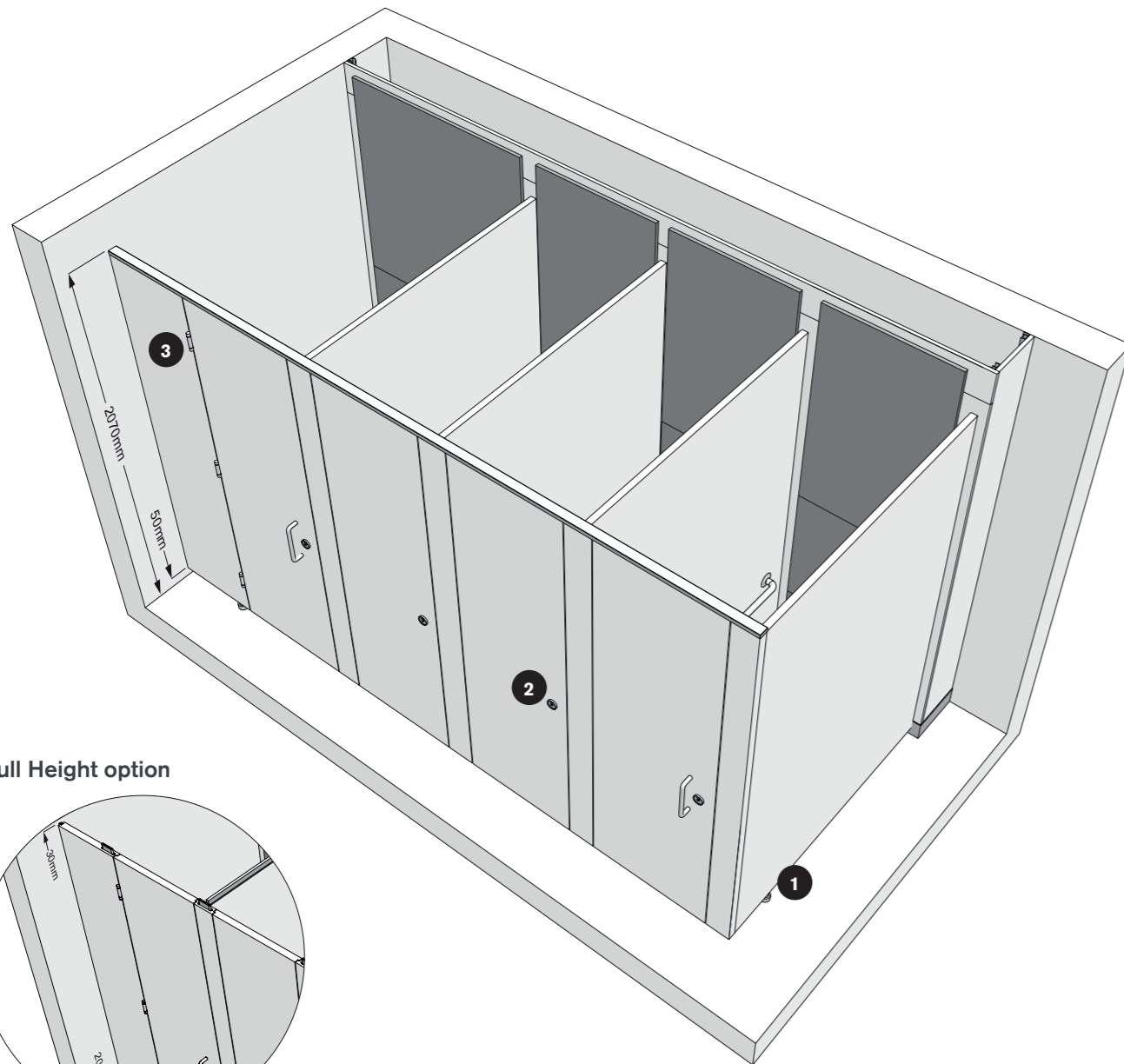

Full Height option

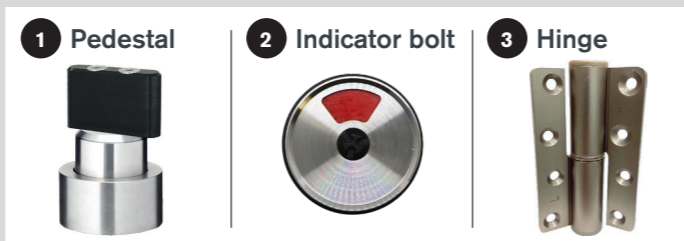
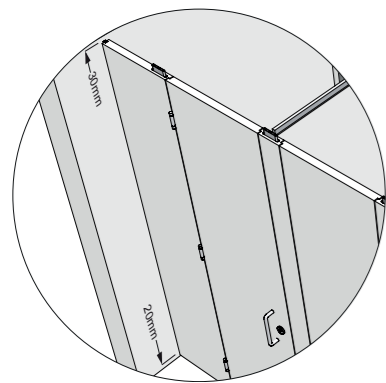

Dimensions

Infinite

Overall height
2070mm

Maximum height
2840mm

Maximum depth
2095mm

Floor clearance
50mm

Minimum ceiling clearance
20mm

Infinite Full Height
Maximum height
2820mm

Maximum depth
2045mm

Floor clearance
20mm

Minimum ceiling clearance
30mm

Bespoke

Infinite cubicles can be specified in various configurations, the images on pages 84-87 are indicative of what can be achieved using a combination of components available.

Performance

Available in four material options, Infinite is suitable for even the most prestigious environments allowing you to specify with confidence.

HPL

Doors and pilasters are 44mm nominal thickness with an MDF core, partitions are 25mm nominal thickness.

ColourCoat

Doors and pilasters are 44mm nominal thickness MDF, partitions are 25mm MDF, both are sprayed with a coat of primer and finished with 20% gloss pigmented lacquer.

ColourCoat High Gloss

Doors and pilasters are 44mm nominal thickness MDF, partitions are 25mm MDF, both are sprayed with a coat of primer and finished with 80% gloss pigmented lacquer.

Veneer

Doors and pilasters are 44mm nominal thickness chipboard faced with real wood veneer, partitions are 25mm MDF core faced with real wood veneer. Door, pilaster and partition edging in complementing ABS from the Venesta standard colour range.

Detailing

Panels and doors

Available in HPL, ColourCoat, ColourCoat High Gloss and Veneer.

Colour finish

HPL
34 colours from the standard range.
ColourCoat and ColourCoat High Gloss
Any RAL classic colour, excluding metallic and fluorescent colours.

Veneer

11 Alpi real wood veneers (varying price points).

Cubicle hardware

Stainless steel and aluminium.

Edge treatment

HPL
Matching ABS lipping.
ColourCoat
Edges are sprayed with one coat of primer and finished with 20% gloss pigmented polyurethane lacquer.

ColourCoat High Gloss

Edges are sprayed with one coat of primer and finished with 80% gloss pigmented polyurethane lacquer.

Veneer

Complementing ABS edging from the standard range.

Headrail (Infinite only)

Slimline profile satin anodised aluminium headrail with 3 part fixing system allowing cubicles to finish 20mm below ceiling height. Stainless steel end cap.

Cubicle hardware

Indicator bolt

Stainless steel indicator bolt with slimline mortice lock and unique emergency release function.

Hinge

Stainless steel effect aluminium hinge with outward opening option available.

Pedestal

Infinite: Adjustable stainless steel pedestal.
Infinite Full Height: Stainless steel effect aluminium fixing blocks to floor and ceiling.

Fixings

Partition to wall: satin anodised aluminium U-channel and Z-clips.

Pilaster to partition: stainless steel Z-clips.

Pilaster to wall: satin anodised aluminium U-channel and Z-clips.

Floor and ceiling fixing: stainless steel effect aluminium fixing blocks (Infinite Full Height only).

Accessories

Coat hooks and toilet roll holders available.